

Varispeed G5/F7/G7 OPTION CARD
PG SPEED CONTROL CARD PG-X2
INSTRUCTIONS

Upon receipt of the product and prior to initial operation, read these instructions thoroughly and retain them for future reference.



Copyright © 2004 YASKAWA ELECTRIC CORPORATION

All rights reserved. No part of this publication may be reproduced, stored in a retrieval system, or transmitted, in any form, or by any means, mechanical, electronic, photocopying, recording, or otherwise, without the prior written permission of Yaskawa. No patent liability is assumed with respect to the use of the information contained herein. Moreover, because Yaskawa is constantly striving to improve its high-quality products, the information contained in this manual is subject to change without notice. Every precaution has been taken in the preparation of this manual. Nevertheless, Yaskawa assumes no responsibility for errors or omissions. Neither is any liability assumed for damages resulting from the use of the information contained in this publication.

NOTES FOR SAFE OPERATION

Before installation, operation, maintenance or inspection of this option, a technically qualified individual who is familiar with this type of equipment and the hazards involved should read this entire manual thoroughly. In this manual, the NOTES FOR SAFE OPERATION are classified as "CAUTION".



Indicates a potentially hazardous situation that, if not avoided, may result in minor or moderate injury to personnel and damage equipment.

Failure to heed notices labeled with  may result in dangerous situations or equipment damage.



Steps to be taken to insure proper operation and to avoid malfunctions.

CAUTION

- The option card uses a CMOS IC chip. It may break if touched by bare fingers because of static electricity. Be careful when handling.
- When removing the option card from the drive for transportation or storage, the card should be placed in the anti-static package it was received in.
- DO NOT alter wiring or connect or disconnect connectors while equipment power is ON.

Failure to observe these cautions may result in injury or equipment damage!



Before use,

1. Before installing the Encoder (PG) Feedback Card (the PG-X2 card), read this manual and the manual for the installation of the drive.
 2. Before connecting the PG-X2 card or external terminals, turn OFF the main power to the drive and verify that the CHARGE indicator lamp of the Drive is OFF.
 3. When ordering the PG-X2 card, specify the product type and code number.
-

WARRANTY INFORMATION

■ Free Warranty Period and Scope

■ Warranty Period

This product is warranted for twelve months after being delivered to Yaskawa's customer or if applicable eighteen months from the date of shipment from Yaskawa's factory whichever comes first.

■ Scope of Warranty

Inspections

Periodic inspections must be conducted by the customer. However, upon request, Yaskawa or one of Yaskawa's Service Centers can inspect the product for a fee. In this case, if after conferring with the customer, a Yaskawa product is found to be defective due to Yaskawa workmanship or materials and the defect occurs during the warranty period, then this fee will be waived and the problem remedied free of charge.

Repairs

If a Yaskawa product is found to be defective due to Yaskawa workmanship or materials and the defect occurs during the warranty period, Yaskawa will provide a replacement, repair the defective product, and provide shipping to and from the site free of charge.

However, if the Yaskawa Authorized Service Center determines that the problem with a Yaskawa product is not due to defects in Yaskawa's workmanship or materials, then the customer will be responsible for the cost of any necessary repairs. Some problems that are outside the scope of this warranty are:

- Problems due to improper maintenance or handling, carelessness, or other reasons where the customer is determined to be responsible.
- Problems due to additions or modifications made to a Yaskawa product without Yaskawa's understanding.
- Problems due to the use of a Yaskawa product under conditions that do not meet the recommended specifications.
- Problems caused by natural disaster or fire.
- Or other problems not due to defects in Yaskawa workmanship or materials.

Warranty service is only applicable within Japan.

However, after-sales service is available for customers outside of Japan for a reasonable fee. Contact your local Yaskawa representative for more information.

■ Exceptions

Any inconvenience to the customer or damage to non-Yaskawa products due to Yaskawa's defective products whether within or outside the warranty period are NOT covered by this warranty.

■ Restrictions

- The PG-X2 card was not designed or manufactured for use in devices or systems that may directly affect or threaten human lives or health.
- Customers who intend to use the product described in this manual for devices or systems relating to transportation, health care, space aviation, atomic or electric power, or underwater use must contact their Yaskawa representatives or the nearest Yaskawa sales office beforehand.
- This product has been manufactured under strict quality-control guidelines. However, if this product is to be installed in any location where failure of this product could involve or result in a life-and-death situation or loss of human life or in a facility where failure may cause a serious accident or physical injury, safety devices must be installed to minimize the likelihood of any accident.

Contents

NOTES FOR SAFE OPERATION	3
WARRANTY INFORMATION	4
1 Inspection after Delivery	7
2 Introduction and Component Names	8
3 Installation Procedure	9
3.1 Before Installation	9
3.2 Drive Installation Procedure	9
4 Interconnection	11
5 Wiring	12
5.1 Terminal Functions	12
5.2 Wiring Precautions	13
6 Application of Encoder (PG)	15
7 PG-X2 Card Parameter List	16
Revision History	

1 Inspection after Delivery

 CAUTION
--

- | |
|--|
| <ul style="list-style-type: none">• Verify that the products received are the products ordered. <p>Installation of incorrect product may lead to injury or damage.</p> |
|--|

Prior to shipment, all Yaskawa products undergo rigorous inspection procedures to ensure accuracy and reliability. We recommend checking the following items upon receipt.

- Check that the code number (73600-A015X) and product type (PG-X2) labeled on the actual card correspond to product ordered.
- Check for damage or shortage caused during transportation.

Report any material or manufacturing defects on the card to your Yaskawa representative.

2 Introduction and Component Names

The Encoder (PG) Feedback Card (hereafter referred to the PG-X2 card) is mounted on the drive's control board to provide speed and direction feedback. The drive's control logic can use this information for purposes such as correcting for speed fluctuation caused by motor slip and maintaining the velocity.

Using standard software, the PG-X2 card can be used for closed loop control (Flux Vector or V/F with PG). Standard software does not utilize the marker (C or Z) pulse from the encoder.

The PG-X2 card is compatible with the G5, F7 and G7 Yaskawa drives.

Name	Code No.	Functions
PG speed controller card PG-X2	73600-A015X	<ul style="list-style-type: none"> • Applicable to RS-422 output PG • Phase A and phase B pulse (2-phase pulse) inputs for vector control • Maximum input PG frequency: 300 kHz • Pulse monitor output: RS-422 output

The external appearance and component names are shown in *Fig. 1*

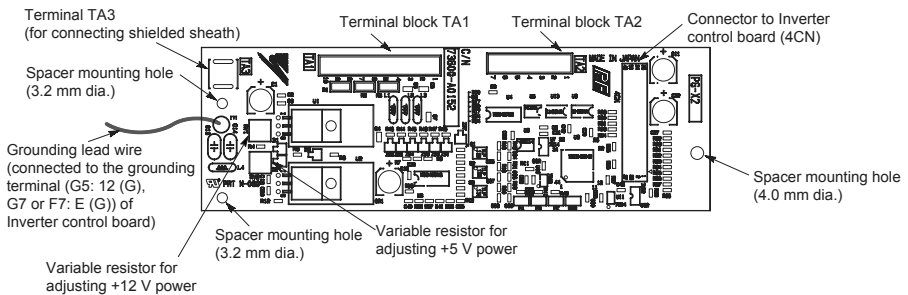

Fig. 1 Encoder (PG) Feedback Card (PG-X2)

3 Installation Procedure

3.1 Before Installation

Remove contents from package and verify that a mounting spacer (code number SRNT41028-9) is included with the PG-X2 card (see *Fig. 2*).

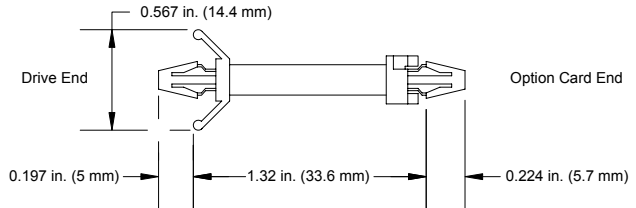
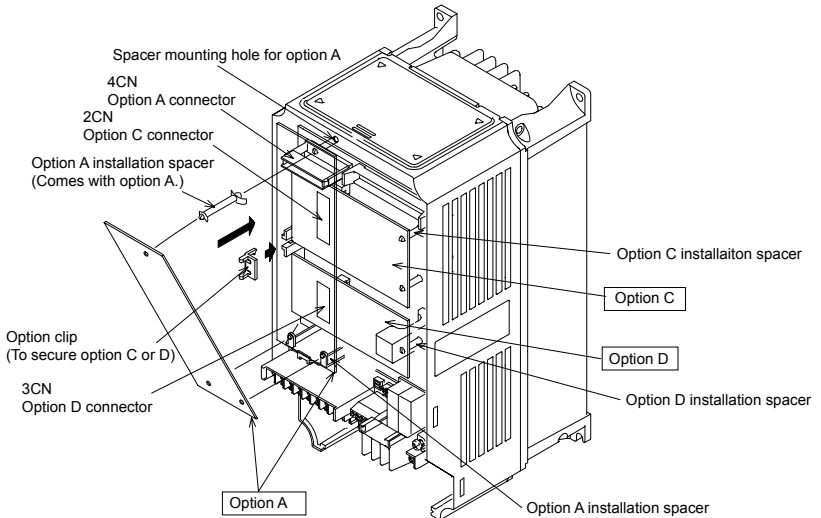
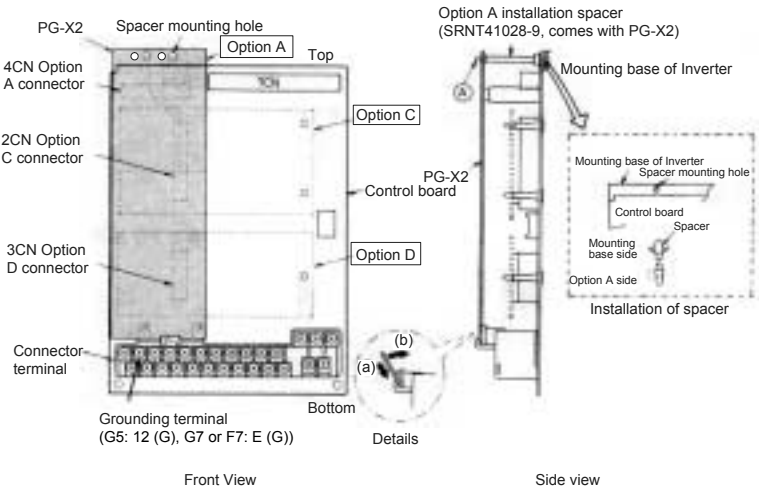

Fig. 2 Spacer

3.2 Drive Installation Procedure

1. Turn OFF the main power and wait for the time specified on the cover of the Drive for voltage to bleed off the DC bus capacitors. Remove the cover and verify that the CHARGE indicator lamp is OFF.
2. Insert the spacer (SRNT41028-9) into the spacer mounting hole in the mounting base of the Drive (see *Fig. 3*). Drive models of 3.7 kW or smaller capacities have two closely spaced mounting holes. Insert the spacer into the hole closest to the 7CN connector on the control board. Insertion of the spacer into the incorrect hole will stack the spacer. Be careful to insert in the proper hole in the proper inserting direction.
3. Align the two holes of the PG-X2 card and projections as shown in the detailed side view, first at location (a) and then at (b), and precisely place the card on the option A connector. Insert the spacer mounted at 2 above into the PG-X2 spacer mounting hole. (See part A of the side view on the next page.)
4. Rotate the top edge of the card down into place, carefully aligning connector 4CN on the back of the card with connector 4CN on the control board.
5. Gently press the card into place until 4CN and the spacer click into place.
6. Connect the grounding lead wire of the PG-X2 card to the grounding terminal (G5: 12 (G), G7 or F7: E (G)) on the control board.



Note: Be sure to remove the option clip before installing the PG-X2 card. If the card is installed with the clip attached, the card cannot be correctly installed, and the card will perform poorly.

Fig. 3 Installation of the PG-X2 Card

4 Interconnection

Fig. 4 shows interconnection between the Drive, the PG-X2 card, and peripheral equipment.

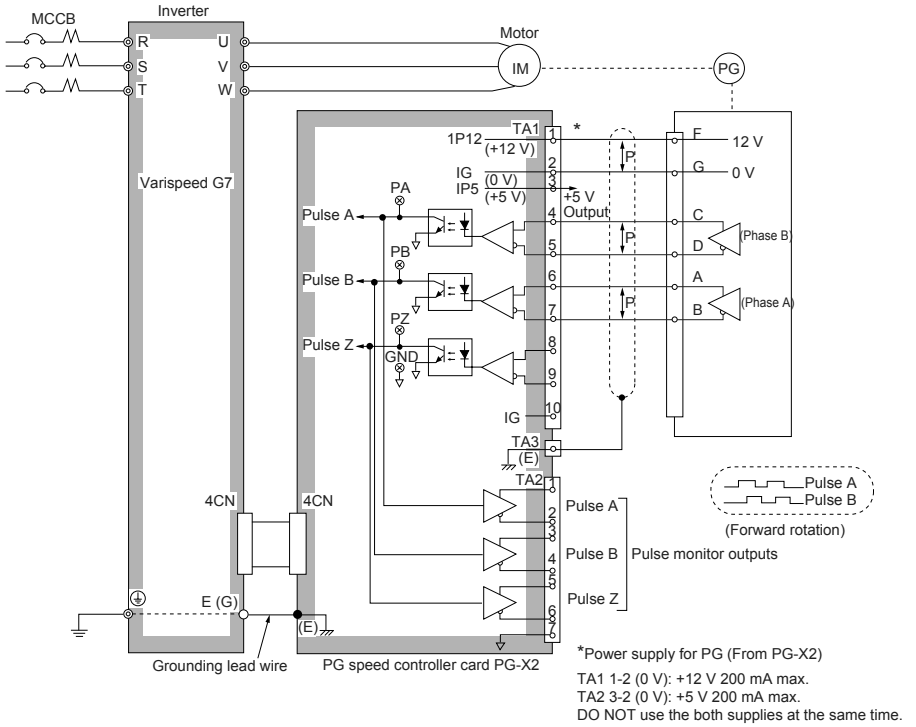

Note: The PG terminal symbols are the examples when using a Yaskawa's motor.

PG type: LMA-□□□BM-□□□ (line-driver output)

Fig. 4 Basic Interconnection Diagram (Example when Used with a G7-series Inverter)

5 Wiring

5.1 Terminal Functions

Table 1 Terminal Functions of PG-X2

Terminal Block Symbol	Pin No.	Functions			
TA1	1	+12 V	Power supply for Encoder (PG) (+12 V, +5 V must not be used at the same time.) +12 V: 200 mA maximum +5 V: 200 mA maximum		
	2	0 V			
	3	5 V			
	4	+	A Pulse	Encoder (Pulse generator, PG) signal input. RS-422 level input.	
	5	-	B Pulse		
	6	+			
	7	-	Z Pulse		
	8	+			
	9	-	Common		
	10	0 V			
TA2	1	+	A Pulse		Pulse monitor output. RS-422 level input.
	2	-	B Pulse		
	3	+			
	4	-	Z Pulse		
	5	+			
	6	-	Common		
	7	SG			
TA3	Shielded sheath connection terminal				

■ PG Signal Output

The PG signal output (phases A and B) may vary according to installation location on the motor. Refer to *Fig. 4* for correct wiring.

In general, motor forward direction is counterclockwise (CCW) as viewed from the load shaft. For YASKAWA's motor, phase A of PG output leads phase B by a phase angle of 90° in clockwise (CW) rotation. According to PG, phase A lags phase B by a phase angle of 90° in clockwise (CW) rotation. In this case, when PG is installed at the opposite drive end, connect phases A and B output from PG to the option card as it is.

For YASKAWA's Inverter motor with PG, PG is installed at the opposite drive end. Then, phase A lags phase B by a phase angle of 90° at motor forward run. (Motor runs CCW as viewed from PG.) Therefore, when using this motor or similar motors, connect phases A and B to the option card after replacing phase output. The pulse monitor on this option shows phase A leading phase B by a phase angle of 90°.

5.2 Wiring Precautions

Make sure of the following when wiring.



- Separate the control signal wires (terminal blocks TA1 and TA2) of the PG-X2 card from the main circuit wires and other power cables.
- Use a shielded wire to connect the encoder (PG). Connect the wires as shown in *Fig. 5* to prevent noise interference. The wire distance must be 328 ft. (100 m) or less.
- To prevent noise, use shielded wire and separate from heavy current circuits (200 VAC or greater) or relay drive circuits. (Wire length to the PG connector must be 328 ft. (100 m) or less.)
- If the PG signal is affected by noise, disconnect the grounding lead wire (E) from the grounding terminal (G5: 12 (G), G7 or F7: E (G)) of the control board of the Inverter. Alternatively, change the location of the shielded sheath connection.
- The recommended tightening torque is 0.22 to 0.25 N·m.

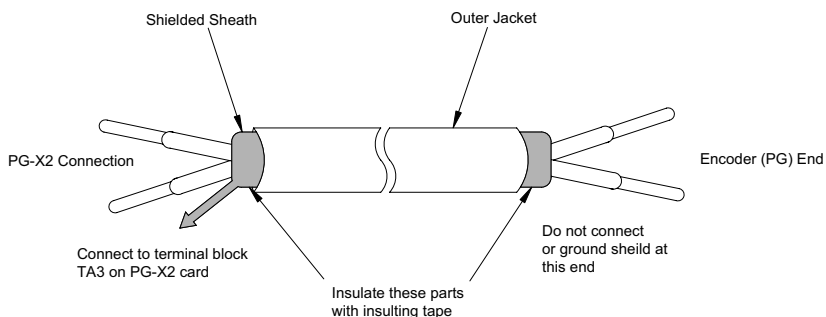

Fig. 5 Shielded Wire Termination

Applicable wire specifications for terminal blocks TA1 and TA2 are shown in *Table 2*.
Terminal: MKDS1 series manufactured by Phoenix Contact GmbH & Co.

Table 2 Wire Specifications

	(mm ²)	AWG	I (amps)	VAC
Thin Twisted Wire	1	16	12	125
Solid Wire	1.5	16	12	125
UL	–	22-16	10	300
CSA	–	28-16	10	300
CSA	–	28-16	10	150

Strip back insulation for a distance of 0.22 inches (5.5 mm) on wire leads connected to the PG-X2 card.

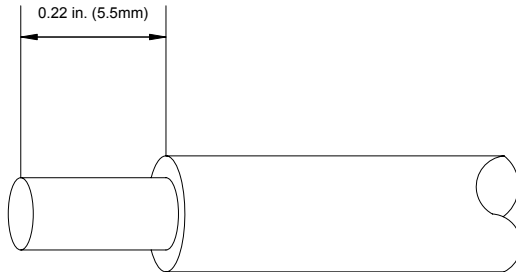

Fig. 6 Connecting Wire End for Terminal Blocks TA1 and TA2 Side



■ Notes on selecting cables

- The thicker a cable is, the greater the pressure on the option card and the greater the possibility of a failure occurring will be.
 - The thinner a cable is, the poorer the electrical contact and the greater the possibility of the conductor breaking will be.
 - The longer the cable is, the more likely a voltage drop in the PG power supply or PG signal will occur.
-

6 Application of Encoder (PG)

The maximum frequency of the encoder (PG) output pulses that can be detected is 300 kHz.

To find the output frequency of your encoder (PG), use the following formula.

$$f_{PG} \text{ (Hz)} = \frac{\text{Motor rotation speed (min}^{-1}\text{) at max. frequency output}}{60} \times \text{Encoder (PG) constant (pulses/rev)}$$

Maximum power available to drive the encoder (PG) with the PG-X2 is 200 mA. Should your encoder (PG) require more than 200 mA, it will be necessary to provide a separate power supply. If momentary power loss ride-through function is necessary, provide backup capacitor or take other necessary measures. See *Fig. 7*.

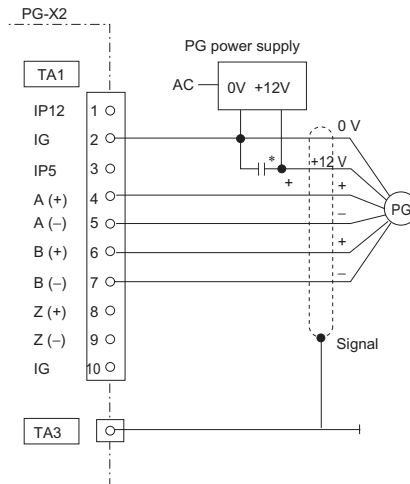

* Backup capacitor momentary power loss recovery

Fig. 7 Connection Example with Encoder (PG) when Using Separate Power Supply

7 PG-X2 Card Parameter List

If using the PG-B2 card with any Yaskawa drives other than the G5, F7, or G7, refer to the instruction manual of the drive being used.

Table 3 PG-X2 Card Parameter List

PG-X2 Card Parameter List												
Digital Operator Function Group	Digital Operator Display	Parameter No.	Parameter Name	Setting Range	Factory Setting	Change During Operation ^{*1}	Data Selection	Control Method ^{*2}				
								G5, G7, F7			G7	
								V/f Control	V/f w/PG Fdbk	Open loop Vector		Flux Vector ⁹
PG Option Setup	PG Pulses/Rev	F1-01	PG constant	0 to 60000	600	×		×	○	×	○	×
	PG Fdbk Loss Sel	F1-02	Operation selection at PG open circuit (PGO)	0 to 3	1	×	0: Ramp to Stop 1: Coast to Stop 2: Fast-Stop 3: Alarm Only	×	○	×	○	×
	PG Overspd Sel	F1-03	Operation selection at overspeed (OS)	0 to 3	1	×		×	○	×	○	○
	PG Deviation Sel	F1-04	Operation selection at deviation	0 to 3	3	×		×	○	×	○	○
	PG Rotation Sel	F1-05	PG rotation	0,1	0	×		0:Fwd=CCW 1: Fwd=CW	×	○	×	○
	PG Output Ratio	F1-06	PG division rate	1 to 132	1	×	Effective with PG-B	×	○	×	○	×
	PG Ramp PI/I Sel	F1-07	Integral value during accel/ decel enable/disable	0,1	0	×	0: Disabled 1: Enable	×	○	×	×	×
	PG Overspd Level	F1-08	Overspeed detection level	0 to 120 %	115 %	×		×	○	×	○	○
	PG Overspd Time	F1-09	Overspeed detection delay-time	0 to 2.0 s	0.0 s ^{*3} (1.0 s) ^{*4}	×		×	○	×	○	○
	PG Deviate Level	F1-10	Excessive speed deviation detection level	0 to 50 %	10 %	×		×	○	×	○	○
	PG Deviate Time	F1-11	Excessive speed deviation detection delay time	0 to 10 s	0.5 s	×		×	○	×	○	○
	PG# Gear Teeth 1	F1-12	Number of PG gear teeth 1	0 to 1000	0	×		×	○	×	×	×
	PG# Gear Teeth 2	F1-13	Number of PG gear teeth 2	0 to 1000	0	×		×	○	×	×	×
	PGO Detect Time ^{*5}	F1-14	PG open-circuit detection time	0 to 10 s	2 s	×		×	○	×	○	×

Table 3 PG-X2 Card Parameter List (cont'd)

PG-X2 Card Parameter List												
Digital Operator Function Group	Digital Operator Display	Parameter No.	Parameter Name	Setting Range	Factory Setting	Change During Operation *1	Data Selection	Control Method *2				
								G5, G7, F7				G7
								V/f Control	V/f w/PG Fdbk	Open loop Vector	Flux Vector*9	
ASR Tuning *6	ASR P Gain 1	C5-01	ASR proportional (P) gain 1	0 to 300.00	20.00 *3 (0.20) *4	○		×	○	×	○	○
	ASR I Time 1	C5-02	ASR integral (I) time 1	0 to 10.000 s	0.500 s *3 (0.200 s) *4	○		×	○	×	○	○
	ASR P Gain 2	C5-03	ASR proportional (P) gain 2	0 to 300.00	20.00 *3 (0.02) *4	○		×	○	×	○	○
	ASR I Time 2	C5-04	ASR integral (I) time 2	0 to 10.000 s	0.500 s *3 (0.050 s) *4	○		×	○	×	○	○
	ASR Limit	C5-05	ASR limit	0.0 to 20 %	5.0 % *4	×		×	○	×	×	×
	ASR Delay Time 1 *8	C5-06	ASR primary delay time 1	0.000 to 0.500 s	0.004 s *3	×		×	×	×	○	○ *3
	ASR Gain SW Freq *8	C5-07	ASR switching frequency	00 to 400.00 Hz	0.0 Hz	×		×	×	×	○	○
	ASR Limit *8	C5-08	ASR integral (I) limit	0 to 400 %	400 %	×		×	×	×	○	○
	ASR Delay Time 2 *7	C5-10	ASR primary delay time 2	0.000 to 0.500 s	0.010 s	×		×	×	×	×	○

* 1. ○ = Enable, × = Disable

* 2. ○ = Setting enable, × = Setting disable

* 3. For flux-vector control

* 4. For V/f with PG feedback control

* 5. For the F7, setting and reference are enabled for the software No. (U1-14) of 1030 or after.

* 6. ASR - Automatic Speed Regulator

* 7. For the G7 only







* 8. If using the flux-vector control with the F7, be sure to use an Inverter with a design revision number of E or later. Versions C or earlier do not support the flux-vector control.

Revision History

The revision dates and numbers of the revised manuals are given on the bottom of the back cover.

MANUAL NO. TOBP C730600 10A

Published in Japan September 2005 04-12 
 └─ Date of publication └─ Date of original publication └─ Revision number

Date of Publication	Rev. No.	Section	Revised Content
December 2004	—	—	New edition that was created by binding together the Japanese version (TO-C736-40.4) and the English version (TOE-C736-40.4) of the VARISPEED-616G5 OPTION CARD PG SPEED CONTROLLER CARD PG-X2 INSTRUCTIONS and by adding information on the Varispeed F7 and the Varispeed G7 Inverters.
September 2005		Back cover	Revision: Address
October 2006		WARRANTY INFORMATION	Addition: Warranty Information
		2	Revision: Fig. 1 Encoder (PG) Feedback Card (PG-X2)
		5.2	Revision: NOTE on Wiring Precautions
May 2007		Back cover	Revision: Revision number
September 2007		Back cover	Revision: Address
January 2008		Back cover	Revision: Address
September 2008		Back cover	Revision: Address
June 2010		Back cover	Revision: Address

Varispeed G5/F7/G7 OPTION CARD PG SPEED CONTROL CARD PG-X2 INSTRUCTIONS

IRUMA BUSINESS CENTER (SOLUTION CENTER)

480, Kamifujisawa, Iruma, Saitama, 358-8555, Japan
Phone: 81-4-2962-5696 Fax: 81-4-2962-6138

YASKAWA ELECTRIC CORPORATION

New Pier Takeshiba South Tower, 1-16-1, Kaigan, Minatoku, Tokyo, 105-6891, Japan
Phone: 81-3-5402-4511 Fax: 81-3-5402-4580
<http://www.yaskawa.co.jp>

YASKAWA ELECTRIC AMERICA, INC.

2121 Norman Drive South, Waukegan, IL 60085, U.S.A.
Phone: (800) YASKAWA (800-927-5292) or 1-847-887-7000 Fax: 1-847-887-7310
<http://www.yaskawa.com>

YASKAWA ELÉTRICO DO BRASIL COMÉRCIO LTDA.

Avenda Fagundes Filho, 620 Bairro Saude, São Paulo, SP04304-000, Brasil
Phone: 55-11-3585-1100 Fax: 55-11-5581-8795
<http://www.yaskawa.com.br>

YASKAWA ELECTRIC EUROPE GmbH

Hauptstraße 185, 65760 Eschborn, Germany
Phone: 49-6196-569-300 Fax: 49-6196-569-398

YASKAWA ELECTRIC UK LTD.

1 Hunt Hill Orchardton Woods, Cumbernauld, G68 9LF, United Kingdom
Phone: 44-1236-735000 Fax: 44-1236-458182

YASKAWA ELECTRIC KOREA CORPORATION

7F, Doore Bldg. 24, Yeoido-dong, Youngdungpo-Ku, Seoul, 150-877, Korea
Phone: 82-2-784-7844 Fax: 82-2-784-8495

YASKAWA ELECTRIC (SINGAPORE) PTE. LTD.

151 Lorong Chuan, #04-02A, New Tech Park, 556741, Singapore
Phone: 65-6282-3003 Fax: 65-6289-3003

YASKAWA ELECTRIC (SHANGHAI) CO., LTD.

No. 18 Xizang Zhong Road, Room 1702-1707, Harbour Ring Plaza, Shanghai, 200001, China
Phone: 86-21-5385-2200 Fax: 86-21-5385-3299

YASKAWA ELECTRIC (SHANGHAI) CO., LTD. BEIJING OFFICE

Room 1011A, Tower W3 Oriental Plaza, No. 1 East Chang An Ave.,
Dong Cheng District, Beijing, 100738, China
Phone: 86-10-8518-4086 Fax: 86-10-8518-4082

YASKAWA ELECTRIC TAIWAN CORPORATION

9F, 16, Nanking E. Rd., Sec. 3, Taipei, Taiwan
Phone: 886-2-2502-5003 Fax: 886-2-2505-1280



YASKAWA ELECTRIC CORPORATION

YASKAWA

In the event that the end user of this product is to be the military and said product is to be employed in any weapons systems or the manufacture thereof, the export will fall under the relevant regulations as stipulated in the Foreign Exchange and Foreign Trade Regulations. Therefore, be sure to follow all procedures and submit all relevant documentation according to any and all rules, regulations and laws that may apply. Specifications are subject to change without notice for ongoing product modifications and improvements.
© 2004-2010 YASKAWA ELECTRIC CORPORATION. All rights reserved.

MANUAL NO. TOBP C730600 10B

Published in Japan June 2010 04-12 ◊-0
10-3-3